

TECHNICAL CATALOGUE

ECOLOGICAL
BALL VALVES: GREEN®





ITAP SpA, founded in Lumezzane (Brescia) in 1972, is currently one of the leading production companies in Italy of valves, fittings and distribution manifolds for plumbing and heating systems. Thanks to fully automated production processes, with 63 tooling machines and 25 assembly lines, we are able to produce 150,000 pieces per day. Our innate pursuit for innovation and observance of technical regulations in force is supported by the company certification ISO 9001: 2008. The company has always considered its focus on quality as the main tool to obtaining significant business results: today ITAP SpA is proud to offer products bearing the approval of numerous international certifying bodies.

ECOLOGICAL BALL VALVES: GREEN®

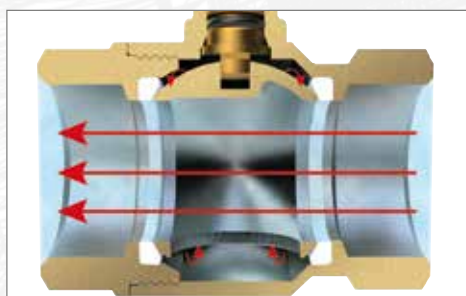

- ECOLOGICAL BALL VALVES IN COMPLIANCE WITH THE NEW EUROPEAN REGULATION FOR DRINKABLE WATER.
- APPROVED IN ACCORDANCE WITH STANDARD **EN 13828** AND CODE OF PRACTICE **DVGW W 570** FOR THE DISTRIBUTION OF WATER INTENDED FOR HUMAN CONSUMPTION.
- EQUIPPED WITH A BALL DESIGNED TO AVOID THE STAGNATION OF WATER AND EVENTUAL PROLIFERATION OF BACTERIA INSIDE THE VALVE.

376

GREEN® BALL VALVE, FULL FLOW



SIZE	PRESSURE	CODE	PACKING
1/4" (DN 8)	50bar/725psi	376B014	12/156
3/8" (DN 10)	50bar/725psi	376B038	12/156
1/2" (DN 15)	50bar/725psi	376B012	10/80
3/4" (DN 20)	40bar/580psi	376B034	8/64
1" (DN 25)	40bar/580psi	376B100	6/48
1"1/4 (DN 32)	30bar/435psi	376B114	4/24
1"1/2 (DN 40)	30bar/435psi	376B112	2/18
2" (DN 50)	25bar/362,5psi	376B200	2/14

TECHNICAL SPECIFICATIONS

Female/female threads.
 Flat lever handle in lined steel.
 Body in nickel-plated brass.
 Minimum and maximum working temperatures:
 -20°C, 150°C in absence of steam.
 Female threads: ISO 7/1 Rp parallel
 (equivalent to DIN EN 10226-1 and BS EN 10226-1).

MATERIALS

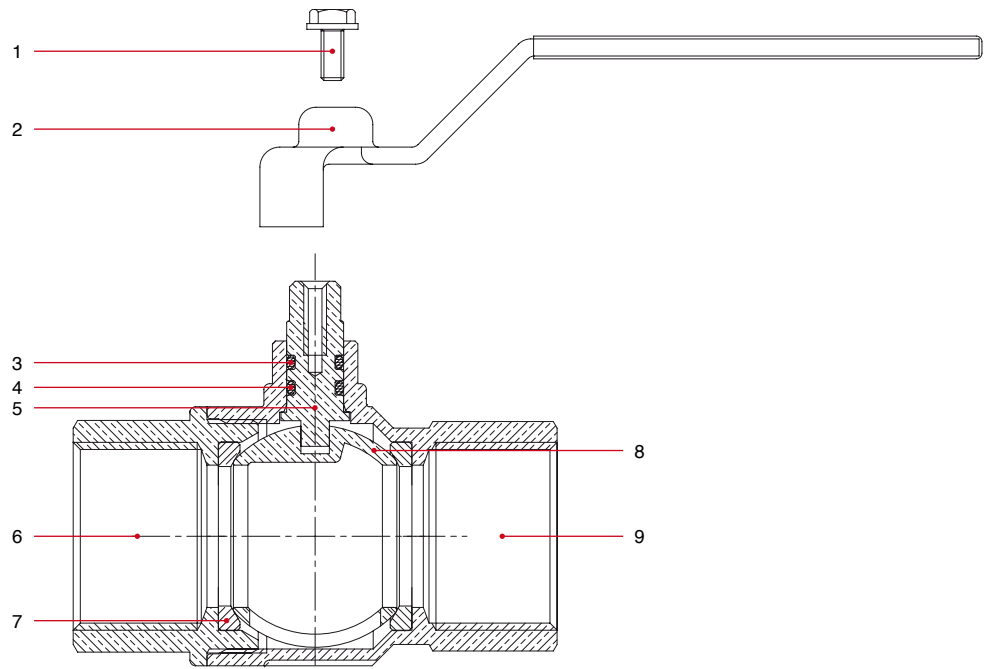

POS.	DESCRIPTION	N.	MATERIAL
1	Screw	1	Zinc-plated steel Fe CB4
2	Flat lever handle	1	Zinc-plated and plastic coated steel Fe.P04
3	O-Ring	1	VITON®
4	O-Ring	1	NBR
5	Stem	1	Brass CW614N
6	End adapter	1	Nickel-plated brass CW617N
7	Seat	2	P.T.F.E.
8	Ball	1	Chrome-plated brass CW617N
9	Body	1	Nickel-plated brass CW617N



OVERALL DIMENSIONS

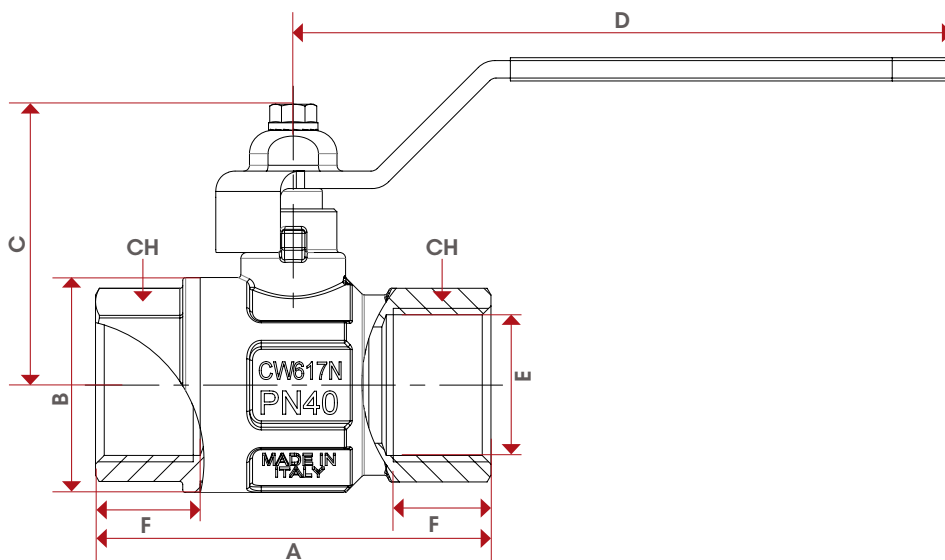

	1/4"	3/8"	1/2"	3/4"	1"	1"1/4	1"1/2	2"
DN	8	10	15	20	25	32	40	50
A	49,5	52,4	61	68	85	99,5	109	130
B	23,5	24	30,5	37	45,5	58	71	85
C	41,8	41,8	50,3	56,3	60,3	76,3	91,8	98,8
D	85,5	85,5	92,5	113,5	113,5	138	158	158
E	10	10	15	20	25	32	40	50
F	11	11,4	15	16,3	19,1	21,4	21,4	25,7
CH	18	21	25	31	38	47	54	66
Kg/cm ² bar	50	50	50	40	40	30	30	25
LBS - psi	725	725	725	580	580	435	435	362,5

CERTIFICATIONS



377

GREEN® BALL VALVE,
FULL FLOW



SIZE	PRESSURE	CODE	PACKING
1/4" (DN 8)	50bar/725psi	377B014	12/156
3/8" (DN 10)	50bar/725psi	377B038	12/156
1/2" (DN 15)	50bar/725psi	377B012	10/80
3/4" (DN 20)	40bar/580psi	377B034	8/64
1" (DN 25)	40bar/580psi	377B100	6/48
1"1/4 (DN 32)	30bar/435psi	377B114	4/24
1"1/2 (DN 40)	30bar/435psi	377B112	2/18
2" (DN 50)	25bar/362,5psi	377B200	2/14

TECHNICAL SPECIFICATIONS

Male/female threads.
Flat lever handle in lined steel.
Body in nickel-plated brass.
Minimum and maximum working temperatures:
-20°C, 150°C in absence of steam.
Female threads: ISO 7/1 Rp parallel
(equivalent to DIN EN 10226-1 and BS EN 10226-1).
Male threads: ISO 7/1 R taper
(equivalent to DIN EN 10226-1 and BS EN 10226-1).

MATERIALS

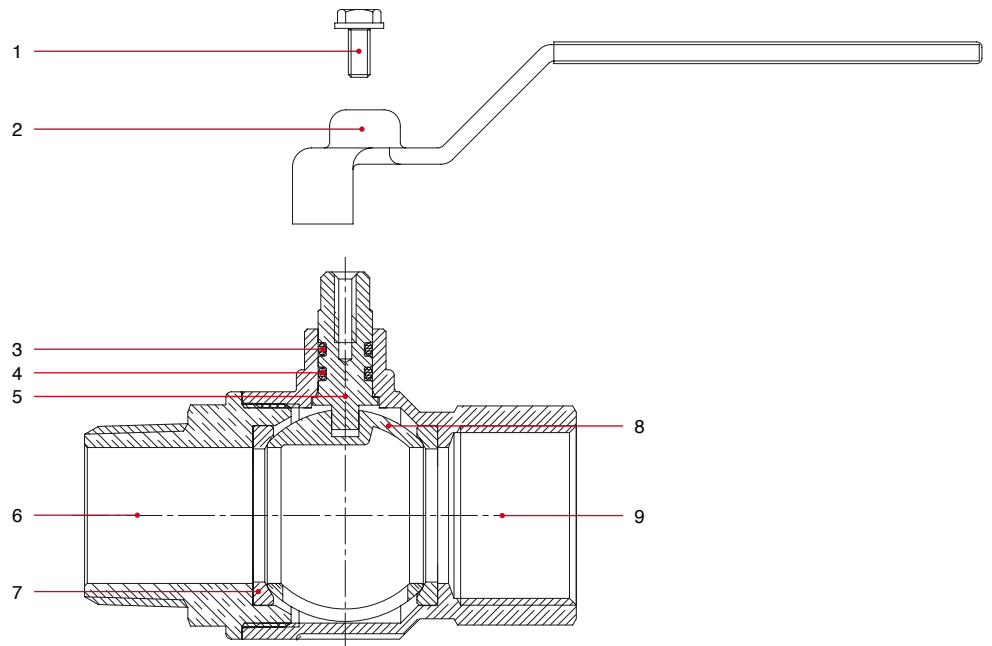

POS.	DESCRIPTION	N.	MATERIAL
1	Screw	1	Zinc-plated steel Fe CB4
2	Flat lever handle	1	Zinc-plated and plastic coated steel Fe.P04
3	O-Ring	1	VITON®
4	O-Ring	1	NBR
5	Stem	1	Brass CW614N
6	End adapter	1	Nickel-plated brass CW617N
7	Seat	2	P.T.F.E.
8	Ball	1	Chrome-plated brass CW617N
9	Body	1	Nickel-plated brass CW617N



OVERALL DIMENSIONS

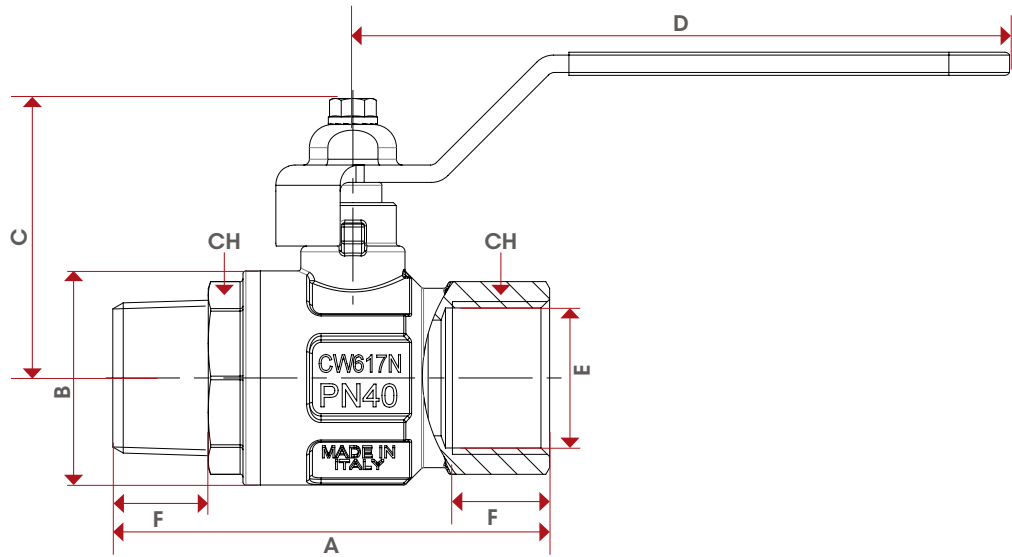

	1/4"	3/8"	1/2"	3/4"	1"	1 1/4"	1 1/2"	2"
DN	8	10	15	20	25	32	40	50
A	56,9	58,9	68	75,5	90,5	105	115,5	135,5
B	23,5	24	30,5	37	45,5	58	71	85
C	41,8	41,8	50,3	56,3	60,3	76,3	91,8	98,8
D	85,5	85,5	92,5	113,5	113,5	138	158	158
E	8	10	15	20	25	32	40	50
F	11	11,4	15	16,3	19,1	21,4	21,4	25,7
CH	18	21	25	31	38	47	54	66
Kg/cm ² bar	50	50	50	40	40	30	30	25
LBS - psi	725	725	725	580	580	435	435	362,5

CERTIFICATIONS



378

GREEN® BALL VALVE,
FULL FLOW



SIZE	PRESSURE	CODE	PACKING
1/4" (DN 8)	50bar/725psi	378B014	15/165
3/8" (DN 10)	50bar/725psi	378B038	15/165
1/2" (DN 15)	50bar/725psi	378B012	10/110
3/4" (DN 20)	40bar/580psi	378B034	8/64
1" (DN 25)	40bar/580psi	378B100	6/48

TECHNICAL SPECIFICATIONS

Female/female threads.

T handle in aluminium.

Body in nickel-plated brass.

Minimum and maximum working temperatures:

-20°C, 150°C in absence of steam.

Female threads: ISO 7/1 Rp parallel

(equivalent to DIN EN 10226-1 and BS EN 10226-1).

MATERIALS

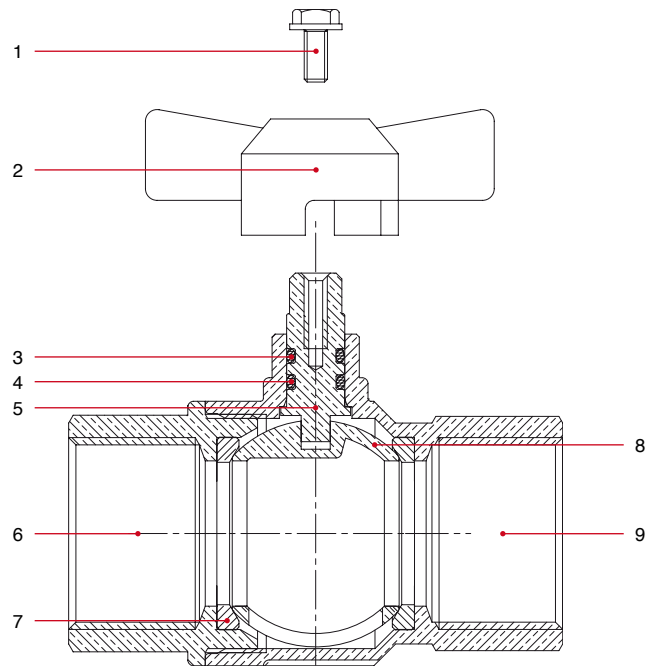

POS.	DESCRIPTION	N.	MATERIAL
1	Screw	1	Zinc-plated steel Fe CB4
2	T handle	1	Varnished aluminium
3	O-Ring	1	VITON®
4	O-Ring	1	NBR
5	Stem	1	Brass CW614N
6	End adapter	1	Nickel-plated brass CW617N
7	Seat	2	P.T.F.E.
8	Ball	1	Chrome-plated brass CW617N
9	Body	1	Nickel-plated brass CW617N



OVERALL DIMENSIONS

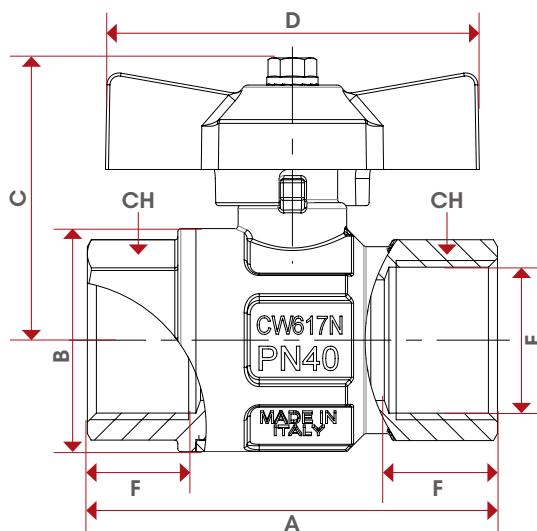

	1/4"	3/8"	1/2"	3/4"	1"
DN	8	10	15	20	25
A	49,5	52,4	61	68	85
B	23,5	24	30,5	37	45,5
C	37,3	37,3	43,8	46,8	50,8
D	47	47	54	62	62
E	10	10	15	20	25
F	11	11,4	15	16,3	19,1
CH	18	21	25	31	38
Kg/cm ² bar	50	50	50	40	40
LBS - psi	725	725	725	580	580

CERTIFICATIONS



379

GREEN® BALL VALVE,
FULL FLOW



SIZE	PRESSURE	CODE	PACKING
1/4" (DN 8)	50bar/725psi	379B014	15/165
3/8" (DN 10)	50bar/725psi	379B038	15/165
1/2" (DN 15)	50bar/725psi	379B012	10/130
3/4" (DN 20)	40bar/580psi	379B034	8/64
1" (DN 25)	40bar/580psi	379B100	6/48

TECHNICAL SPECIFICATIONS

Male/female threads.
T handle in aluminium.
Body in nickel-plated brass.
Minimum and maximum working temperatures:
-20°C, 150°C in absence of steam.
Female threads: ISO 7/1 Rp parallel
(equivalent to DIN EN 10226-1 and BS EN 10226-1).
Male threads: ISO 7/1 R taper
(equivalent to DIN EN 10226-1 and BS EN 10226-1).

MATERIALS

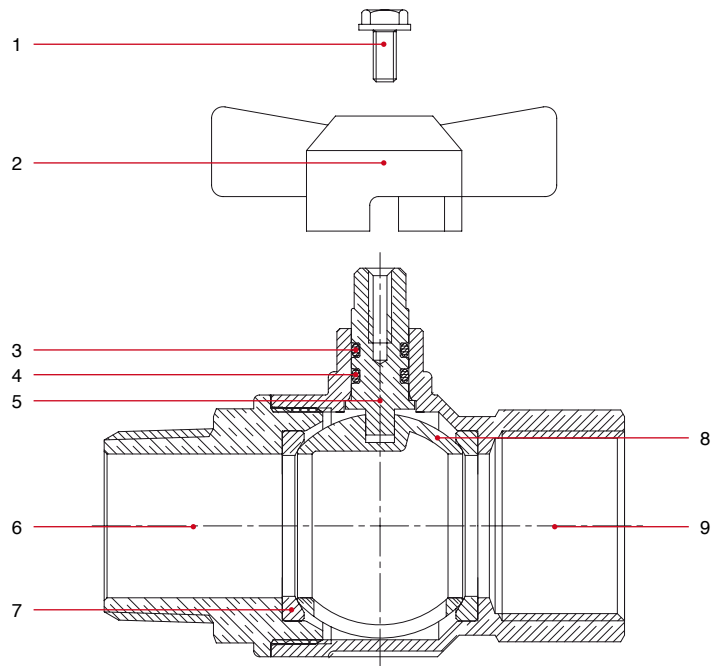

POS.	DESCRIPTION	N.	MATERIAL
1	Screw	1	Zinc-plated steel Fe CB4
2	T handle	1	Varnished aluminium
3	O-Ring	1	VITON®
4	O-Ring	1	NBR
5	Stem	1	Brass CW614N
6	End adapter	1	Nickel-plated brass CW617N
7	Seat	2	P.T.F.E.
8	Ball	1	Chrome-plated brass CW617N
9	Body	1	Nickel-plated brass CW617N



OVERALL DIMENSIONS

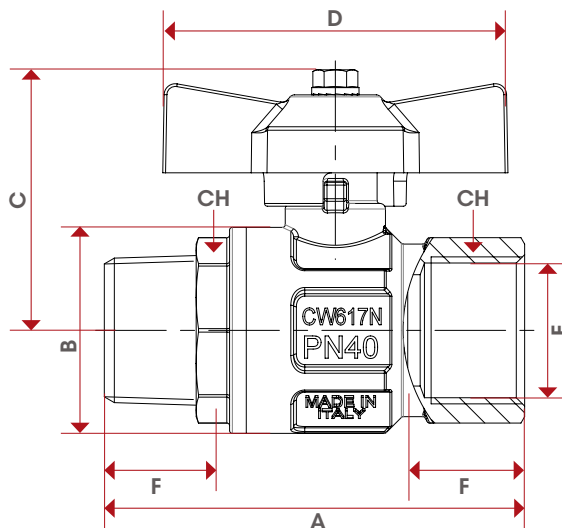

	1/4"	3/8"	1/2"	3/4"	1"
DN	8	10	15	20	25
A	56,9	58,9	68	75,5	90,5
B	23,5	24	30,5	37	45,5
C	37,3	37,3	43,8	46,8	50,8
D	47	47	54	62	62
E	8	10	15	20	25
F	11	11,4	15	16,3	19,1
CH	18	21	25	31	38
Kg/cm ² bar	50	50	50	40	40
LBS - psi	725	725	725	580	580

CERTIFICATIONS



FLOW RATE AND PRESSURE DROP CHART

WITH WATER

Art: 376 - 377 - 378 - 379

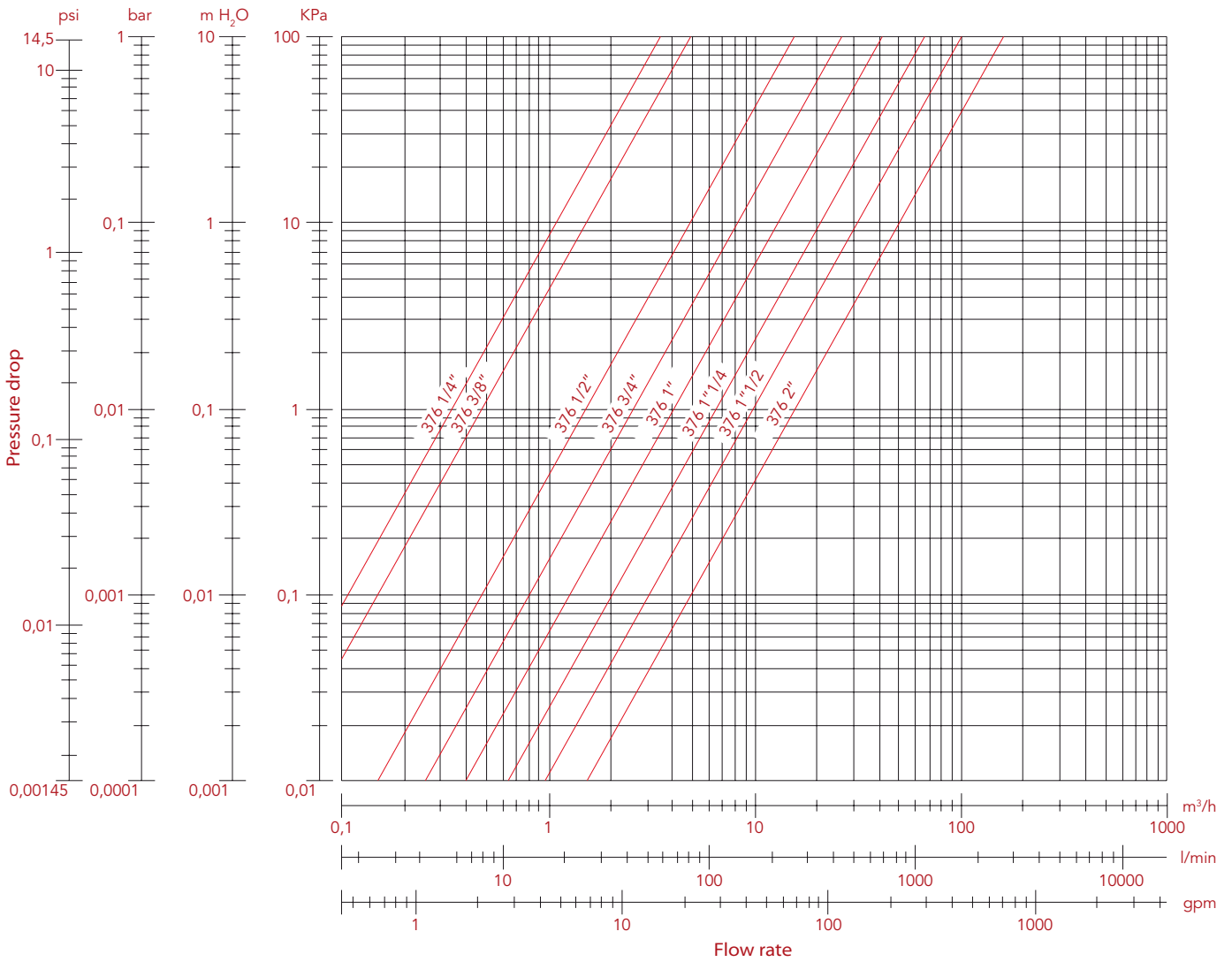

SIZE	1/4"	3/8"	1/2"	3/4"	1"	1 1/4"	1 1/2"	2"
Ø	10	10	15	20	25	32	40	50
Kv	3,21	4,88	15,32	25,96	41,29	63,27	100	167



PRESSURE-TEMPERATURE DIAGRAM

BALL VALVES

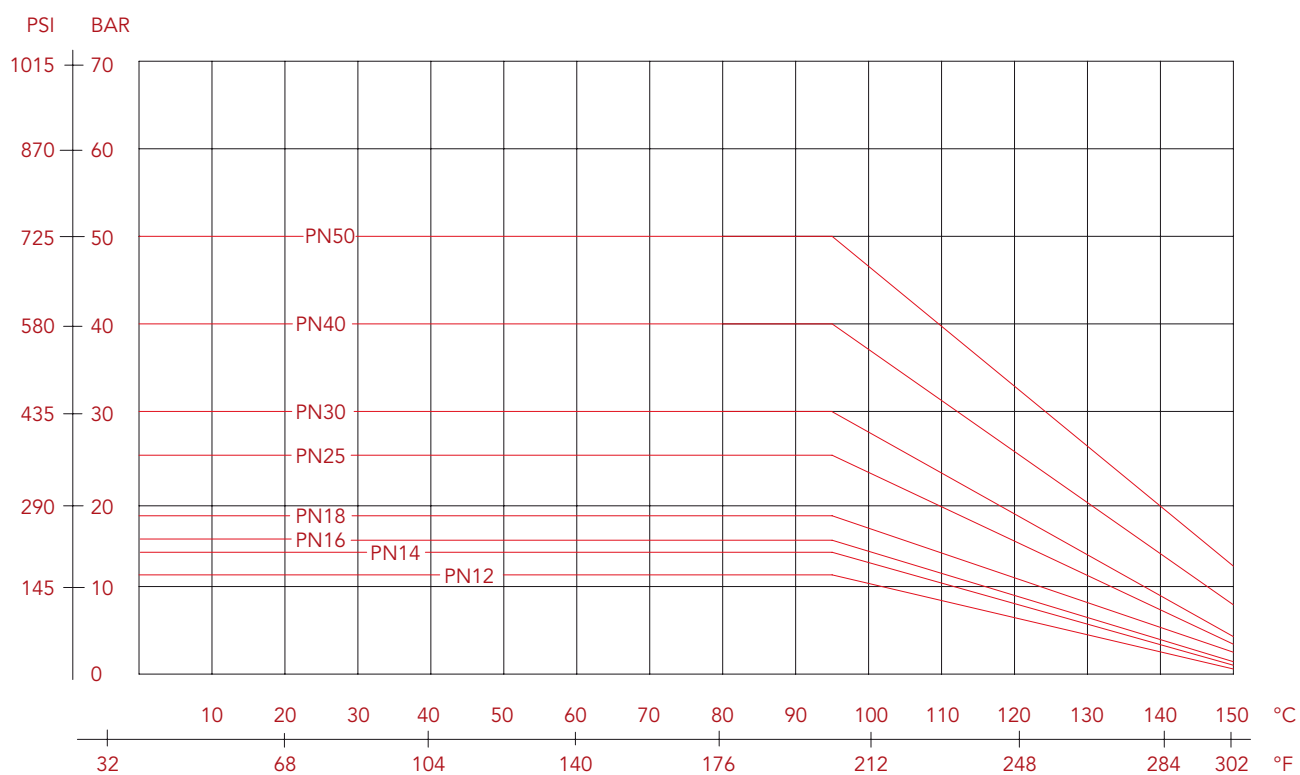

The values shown by the dropping lines state the maximum limit of employment of the valves.
The shown valves are approximate.

MANUFACTURER INSTRUCTIONS

Installation

The itap S.p.A.'s valves are bi-directional, that means they manage the flow in both the directions. The valves are composed by a ball, two seal in PTFE material, one stem, two sailing rings (O-Rings), one handle and a couple of parts made of brass (body and end adopter) that contain them and that are assembled by means of threat and a sealed material to obtain their aim. To avoid that the sealing material gets brake and than the valve gets lose the connection between body and the end adopter, it's necessary to avoid to submit the two parts under the influence of a torque.

For their installation ones have to use the normal hydraulic practices, and in particular:

- Ones have to be sure that the two pipes are correctly aligned,
- during the assembling ones have to apply the assembling tool at the end that is nearest to the pipe,
- the application of the sealing materials by the fitter (PTFE or hempen cloth) must be limited at the threat zone. An excess should interferences in the ball-gasket's closure zone, compromising the tightness.
- In the case that the fluid transported presents some impurities (dust, water too hard, etc.) ones have to remove these impurities by the means of a filter. Otherwise they could damage the seals.

Disassembly the installed valve

To remove the valve from the pipe line or anyhow before to unscrew the junctions linked to it:

- wear the clothing protective normally required to work with the fluid transported within the line.
- Depressurize the line and operate in this way:
 - positioning the valve in opened position and than empty the line
 - handle the valve to put down the residue pressure contained inside the space between the ball and the body before of remove it from the line,
 - during the disassembly apply the screw tool at the end of the valve nearest the pipe

Maintenance

Verify the valves periodically, in function oh their application's field and in function of their work conditions, to be sure that the valves work correctly.

INSTALLATION LOCKING DEVICE FOR LOCKABLE FLAT LEVER HANDLE ART. 084LK

The device has to be used on valves and biblocks with flat lever handle.

When the valve is not equipped with a flat lever handle, it is possible to replace the standard handle as shown in this catalogue, in order to have a lockable valve.

1. Remove the handle from the valve, when you want to have a lockable valve.



2. Replace the handle with the corresponding flat lever handle, in order to have a lockable valve.

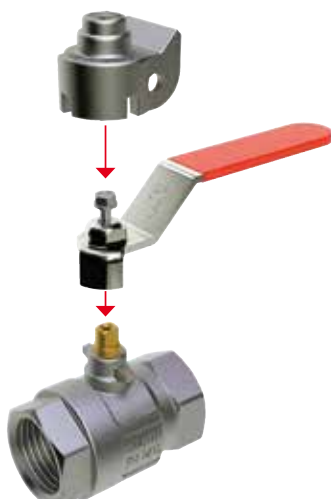

3. Place and lock the locking device either on the open or on the shut-off valve.

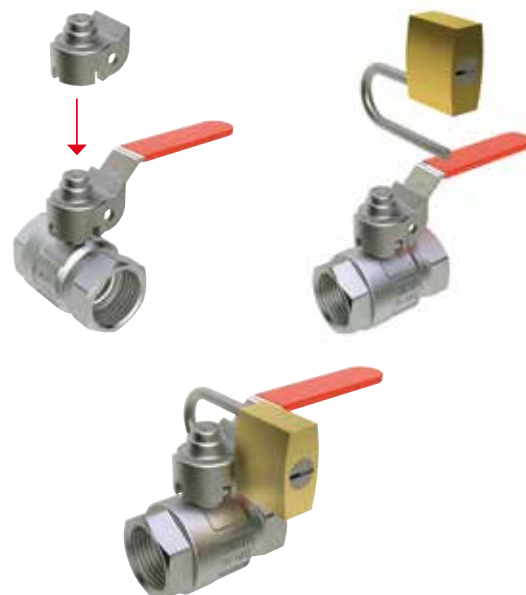

4. Pin for locking device. It is suitable for water and gas ball valves.





NOTES

Lined area for notes with horizontal dashed lines.



ITAP S.p.A.
Via Ruca 19
25065 Lumezzane
Brescia (ITALIA)
Tel 030 89270
Fax 030 8921990
www.itap.it - info@itap.it